

## Packaged submersible pump stations with synthetic collection sump

### SK 6, SK 9

#### Description

SK 6 and SK 9 sumps are pre-assembled submersible pump stations, each with an anti-flotation collection sump for the drainage of buildings from below the sewer level. With the minimum of civil work and installation time it is installed, in open ground, outside the building.

Installing the SK 6 or SK 9 is an effective and economical solution for various waste-water and sewage disposal situations. Both pump stations can be supplied with either HOMA submersible series Barracuda GRP sewage pumps with cutting system, or series TP and series TCV/TCM waste-water pumps.

#### Main features of SK 6 and SK 9:

- Complete pump station including pipe work and valves for a quick, simple installation.
- The low weight and compact design makes it easily transportable.
- Various inlets DN 100/150/200 to accommodate specific conditions.
- No-deposit at the sump bottom, achieved by the hanging pump-coupling and spherical base of the sump, designed to prevent build-up.
- Easy pump removal: the pump can be lifted on its own without the discharge pipe.
- Only SK 9: Frost-free discharge outlet 1100 mm below sump-cover.

#### Design/Equipment supplied

The collection sumps comprises:

**Tank:** compact polyethylene tank with anti-flotation design. SK 6 with 3, SK 9 with 5 tank connections DN 100/ DN 150 inlets including combined cable duct/ air vent and 1 for DN 200 inlet. Discharge pipe outlet. Frame for height support ring or access cover.

**Pump Discharge Equipment:** Auto-coupling system for 1 or 2 pumps with double guide rails (for pump-coupling flange see „Accessories“). Galvanized discharge with screw connections. One or two soft-sealing ball check valves, gate valve. Discharge flush-cleaning connection with Storz-quick coupling. Threaded tank discharge connection BSP 1½" M.



#### Pump Types

Pump range	Spherical clearance (mm)	Impeller design	Motor-output P <sub>2</sub> (kW)	H max. (m)	Q max. (m <sup>3</sup> /h)	Pump discharge size
TP 30 M	30	Single channel	0,7 – 1,2	14 – 19	33 – 43	BSP 2" M
TP 30 V	30	Vortex	0,9 – 1,2	9 – 13	32 – 38	BSP 2" M
TP 50 M	50	Single channel	0,8 – 3,2	7,5 – 30	42 – 82	BSP 2½" M
TP 50 V	50 – 65	Vortex	1,0 – 3,4	8 – 18	41 – 53	BSP 2½" M
TCV	40 – 65	Vortex	0,6 – 1,1	7 – 10	18 – 33	BSP 2" F BSP 2" F
TCM	65	Single channel	1,0 – 1,5	12 – 15	38 – 48	BSP 2½" F
GRP	-	Cutting system	1,1 – 3,1	20 – 35	15 – 28	BSP 2" M

For further information see specific pump literature.

Materials:		Sump Types		
		Type	No. of pumps	Ref. No.
Tank	Polyethylene	SK6-40/1	1	9820120
Pump coupling system	Cast iron, coated	SK6-40/2	2	9820122
Guide rails	Stainless steel	SK9-40/1	1	9820100
Discharge pipe, screw connections	Galvanized steel	SK9-40/2	2	9820102

**Dimensions**

**SK 6-40/1 + SK 6-40/2  
Single- and twin pump station**

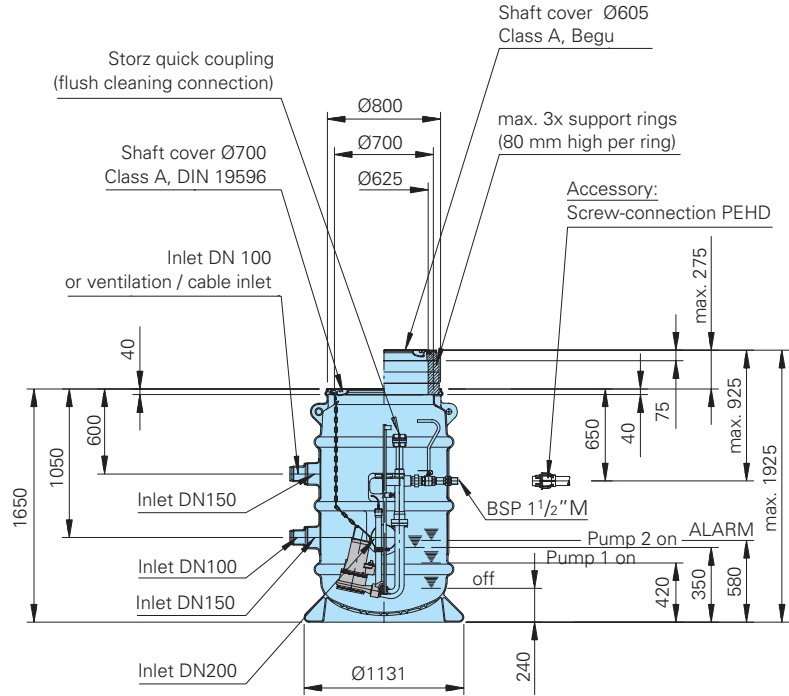

**SK 6-40/2  
Twin pump station**

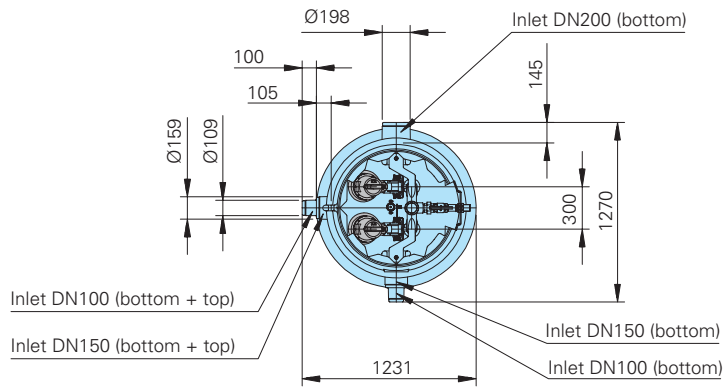

**SK 6-40/1  
Single pump station  
(dimensions same as twin pump station)**

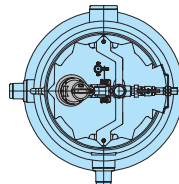

**Dimensions**

**SK 9-40/1 + SK 9-40/2  
Single- and twin pump station**

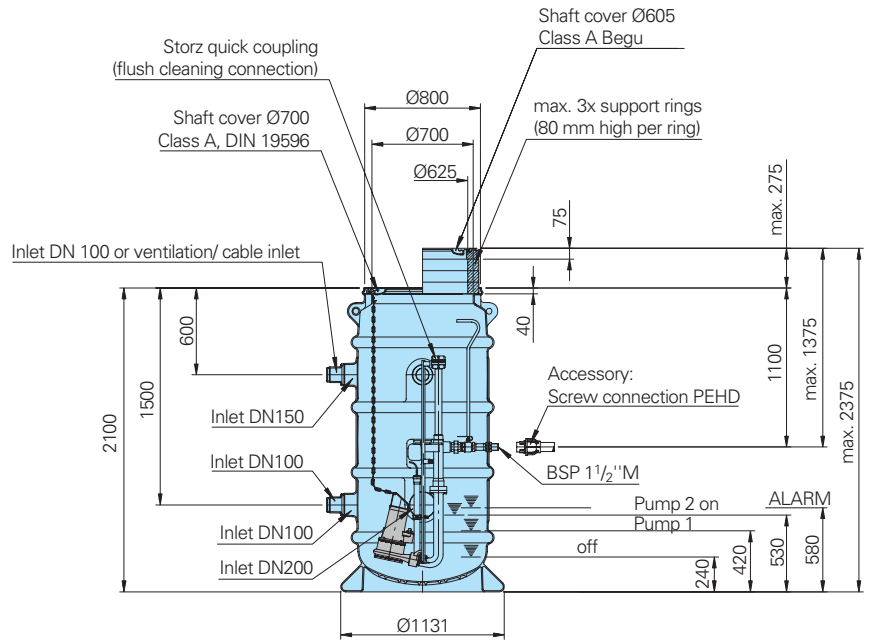

**SK 9-40/2  
Twin pump station**

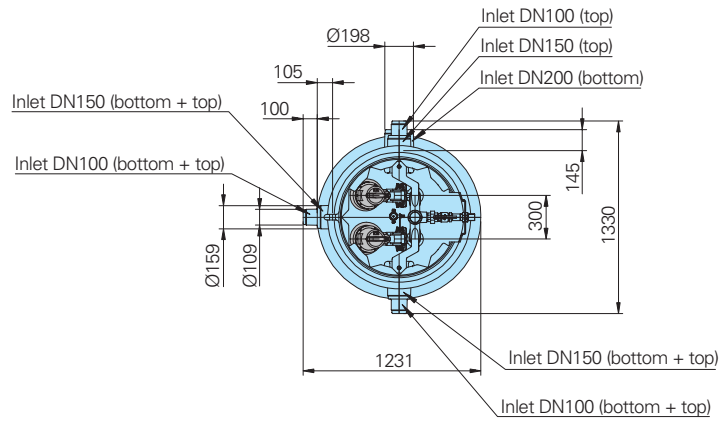

**SK 9-40/1  
Single pump station  
(dimensions same as twin pump station)**

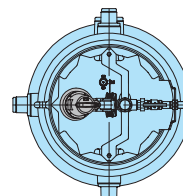

## Installation

SK 9-40/1

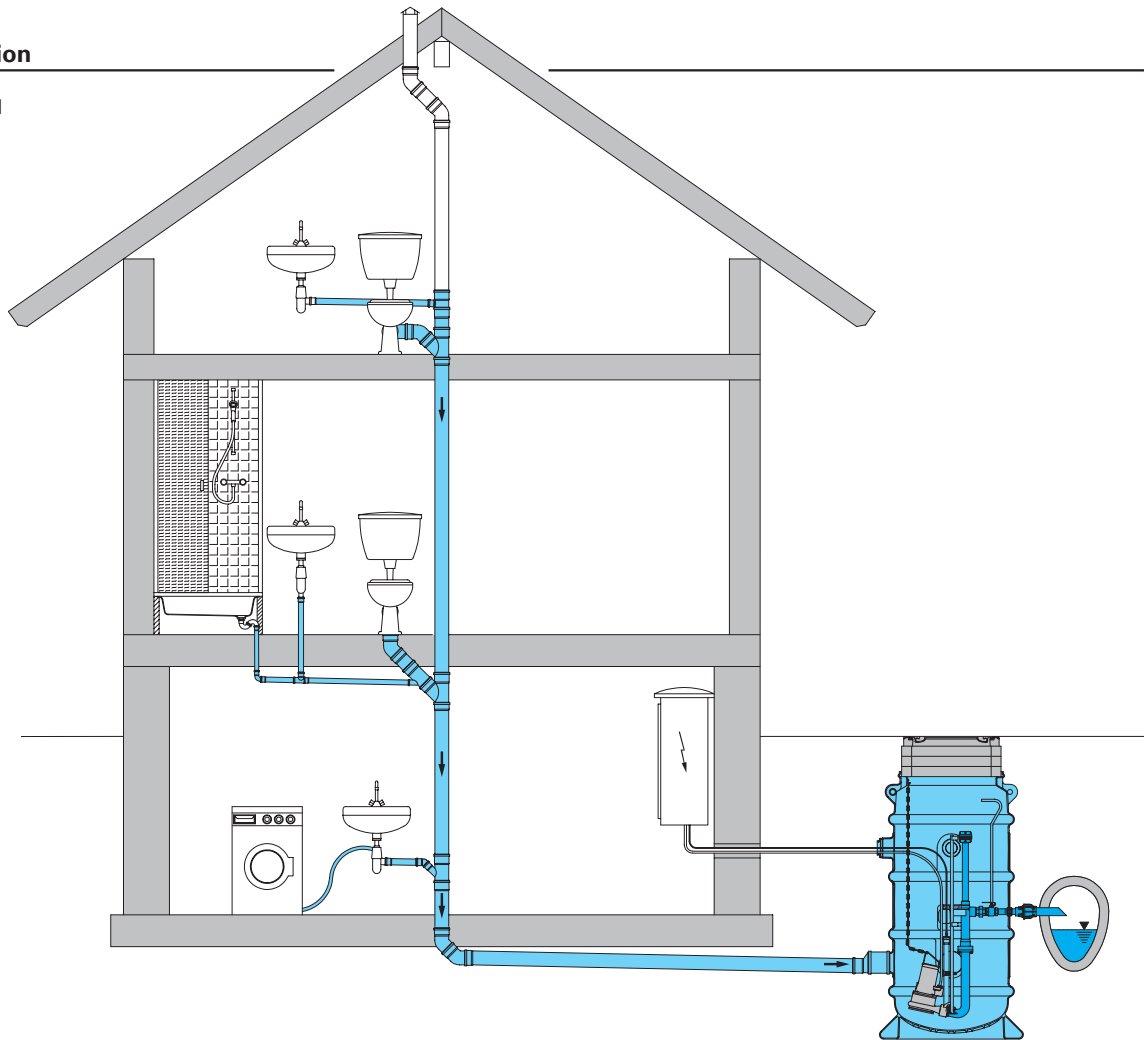

## Accessories

**Pump coupling flange:**  
For connection the selected pump type to the coupling system.

pump coupling flange	for pump type	Ref.No.
BSP 2" M	TCV	7323204
BSP 2" F	TP 30, GRP	7323203
BSP 2 1/2" F	TP 50	7323213
BSP 2 1/2" M	TCM	7323214

### Control panel:

Electronic control panel with plastic housing IP 54. Manual-O-automatic switch. Pilot lights for operation, direction of rotation (3-phase models only), alarm and faults. Overload protection with contractor. Mains-operated alarm with buzzer. Mains-independent alarm connector with battery charger for storage battery. Volt-free contact for remote signal. Pump motor over-temperature protection on pumps with integrated thermal sensors. Operation capacitor or start capacitor (for single-phase models only). Pneumatic level control

with pressure tube, pressure switch and compressor. Twin pump station control panel additionally with auto-change-over after each pump cycle, operation of second pump at high flow, automatic change to stand-by pump in case of pump failure.

Type	Nominal current of the pump	Ref.No.
for 1 pump 400 – 415 V / 3 ph:		
PS12-D2	1,0 – 1,6	8234540
PS12-D3	1,7 – 2,4	8134542
PS12-D4	2,5 – 4,0	8234544
PS12-D6	4,1 – 6,0	8234546
PS12-D9	6,1 – 9,0	8234548
PS15-D2	1,0 – 1,6	8234530
PS15-D3	1,7 – 2,4	8234532
PS15-D4	2,5 – 4,0	8234534
PS15-D6	4,1 – 6,0	8234536
PS15-D9	6,1 – 9,0	8234538
for 2 pumps 400 V / 3 ph:		
PS25-D2	1,0 – 1,6	8234580
PS25-D3	1,7 – 2,4	8234582
PS25-D4	2,5 – 4,0	8234584
PS25-D6	4,1 – 6,0	8234586
PS25-D9	6,1 – 9,0	8234588
Control panels for 230 – 240 V / 1 ph on request.		

**Storage Battery 9.6 V** for mains independent alarm.

**Electronic seal control** of pump oil chamber with alarm at the control panel.

### Sump Cover:

- Cast iron cover, class A. Ref.No. 2804920
- BEGU cover, class A (only usable with concrete rings) Ref.No. 2805005

**Support Rings** of concrete, height 80 mm (max. 3 rings each sump). Ref.No. 2805000

**Vaccum Breaker**, pre-assembled with discharge pipe and T-piece BSP 1 1/2" / BSP 1". Ref.No. 7336604

**Screw-connection** for PEHD-discharge pipe.

- Ø 50 x 4,6 mm Ref.No. 2109160
- Ø 63 x 5,8 mm Ref.No. 2109165

**HOMA**  
P U M P T E C H N O L O G Y

HOMA Pumpenfabrik GmbH  
P.O. Box 22 63, D-53814 Neunk.-Seelscheid  
Tel. ++49(0)22 47/702-0, Fax ++49(0)22 47/702-44  
e-mail: info@homa-pumpen.de  
www.homapumps.com